

ALARM ANNUNCIATOR SHORTFORM BROCHURE



- ❖ ADDA APM4 MICRO CONTROLLER ALARM ANNUNCIATOR SYSTEM.
- ❖ LED BACKLIT INDICATOR SYSTEM FOR USE WITH PLC MULTI 16 PLUS OR AEM4.
- ❖ MLT16 A FULL FUNCTION 16 WAY REMOTE ANNUNCIATOR MODULE EXPANDABLE UP TO 1024 WAYS.
- ❖ ADDA 8G LOW COST RELIABLE STANDARD ALARM SEQUENCE ANNUNCIATOR.
- ❖ AEM4-MASTER & AEM4-SLAVE.
- ❖ AEM4 MICRO CONTROLLER BASED ALARM ANNUNCIATOR SYSTEM WAS DESIGNED FOR USE AS AN INDUSTRIAL RAIL MOUNT ALARM SYSTEM.

Johannesburg Branch



Cape Town Branch



Alarm Annunciators are industrial alarm panels with alarm displays designed to ANNOUNCE critical alarms for an industrial process.

Alarm Annunciators can have some or all of the following functions

- Manual or Auto Reset
- Input Polarity Selection
- First Up Fast Flash
- Ring-back
- Fast or Slow Input Response Time
- Re-initialise
- Status Retention (on Power Failure)
- Inverted outputs
- Auto-Silence

Manual or Auto Reset

Although there are many different defined alarm sequences the two most common are the Manual Reset and the Auto-Reset Sequence.

The Manual Reset has two main Controls an Accept or Acknowledge Button and a Reset Button

On receiving an alarm the alarm is latched (stored). It is normally announced by an audible sound and a flashing display plus the operation of a TRIP output. The Trip output can be used to halt the process or plant. When the alarm is acknowledged the display changes to a steady indication to show the difference between an acknowledged and an unacknowledged alarm. If an alarm has cleared, operation of the Reset control will clear all non-present alarms and trip signals.

Where the Trip has been used to lockout a plant or process often the Reset Button is replaced with a Key Switch so that only a Key Holder can operate the Reset and restart the plant or process. This can be interfaced to a Safety Lockout system so nobody can restart the plant while Maintenance personnel are still working in a dangerous area.

The Auto Reset works on the Acknowledge Control and once an alarm is acknowledged as soon as it clears it AUTO-RESETS.

Input Polarity Selection

Selectable Normally Open or Normally Closed Alarm:

Normally Open : Alarm is activated when a positive input is present.
Normally Closed : Alarm is activated when the positive input is not present.

First Up Fast Flash

This is where the first alarm in a group will flash fast when other alarms occur in the group.

This is to show which alarm started first in a group of alarms and it is often used to reduce the fault finding time where alarms are inter-related.

An example could be a conveyor belt that has interrelated tripping of the motor from multiple sources. On a TRIP event all of these interrelated Alarms would be activated and the FU/FF system would show which Alarm was the originating fault.

RING-BACK

This is mostly used for informing the operator that there has been a change in alarm status. The ring-back signal is a double-blip of 1 second duration operating the horn relay.

In both the Manual and Auto-Reset Sequences there are segments of the sequences where the operator will not know if the alarm is present or has cleared.

The RING-BACK signal tells the operator that there has been a change. In Auto Reset mode the Alarm would just clear automatically and this is indicated to the operator by the RING-BACK blip.

In Manual Reset mode the control switches should be used to see what has changed.

INPUT RESPONSE TIME

This allows for a fast nominal response time of 4 m Sec or a slower debounce time on noisy input lines.

As part of the system for the Alarm Annunciator to distinguish between Transient Signals, Contact Bounce and True Alarm Signals. Different types of signal need different response times. Typically pressure operated sensors such as Bucholz Relays need a very fast response as the desired signal would be ignored as a transient with a slow response setting

Reverse Lamp Logic

Typically used when a window is required to display a "POWER OK" as the normal condition. The standard annunciator functionality is the opposite of what is expected when monitoring a power supply. Inverting the lamp display Logic solves this problem such that the "Normal State" is indicated by the Display being On.

However when the monitored Power Supply fails (in Alarm) The Display will "Flash Slow".

On Acknowledge the Display will go out indicating Failure of the Power Supply by being off. Thus a "POWER OK" alarm window makes sense. While the failure still causes an alarm.

RE-INITIALISE

This function operates in the "Manual Reset Mode" only. When enabled and after a RESET any Alarm still present and in the ACKNOWLEDGED/ACCEPTED STATE will be returned to the Unacknowledged state and treated as a newly arrived Alarm. i.e.: Flashing Led's, GA and Trip relays active. This is used to remind Operators of any Outstanding Alarms

STATUS RETENTION

This feature is activated on a loss of Power. It stores the last known status of the annunciator at the time of the power loss. If activated, upon the restoration of the Power Supply the system will power-up displaying the same status that existed at the time of the power failure.

AUTO SILENCE

For use in un-attended locations, where it is not necessary to have the Horn running continuously until the next operator attends the site. It is therefore possible to set the Annunciator to automatically Silence the Horn. The G.A. relay will deactivate after 10 Min.

ALARM & MODBUS SYSTEMS

We supply both Blind (without display) and Integrated (with built in display) types and for use with the blind units we offer several different stand alone LED displays.

Our offering can be divided up into two basic types.

- 1/ Relay and Diode types mainly for electrical protection panel applications.
- 2/ Microprocessor based Annunciators with user selectable functions for process control.

Relay and Diode Annunciators

These are robust highly reliable units that work with direct voltage or normally open alarm contacts. They can be pre-ordered for Manual Reset or Auto Reset operation

ARM4
ADDA4
ADDA4C
ADDA8 A8PM
ADDA12C
ADDA16
ADDA20C
ADDA24
ADDA8 FLAG

Microprocessor based Annunciators

These are 12 or 24V units that are mainly operated by alarms with voltage free contacts

AEM4
AEM4+D
APM4
MULTI8E

Annunciator Windows

VUE8
VUE16
ADSYS96
Custom Mosaic System

Latched Alarm Annunciator

For customer with systems with latched alarms such as Motor Overload Trips or Fire & Security Alarm Panel outputs. We can offer the low cost SASB 8





S - Normally Stock
L - Limited Stock
O - Ex Order



VUE16-1N-24D 24VDC (Neg. comm.)

VUE16-1P-24D 24VDC (Neg. comm.)

- Jumper selectable colour per window (Red/Green/Amber)
- 34mA / window @ 24V DC (Amber) only 17mA for Red/Green
- Removable terminals
- User laser printable indicator window insert
- Fully solid state - life expectancy > 150 000Hours
- Standard DIN size Bezel (96x192) & Cutout size (90x183)
- Common negative & common positive versions



VUE8

- Dipswitch selectable colour per window (Red/Green/Amber)
- 34mA / window @ 24V DC (Amber) only 17mA for Red/Green
- Removable terminals
- User laser printable indicator window insert
- Fully solid state - life expectancy > 150 000Hours
- Standard DIN size Bezel (44x96) & Cutout size (91x139)
- Common negative & common positive versions



LED BACKLIT INDICATOR SYSTEM for use with PLC, MULTI 16 PLUS or AEM4

Tri-colour select (by input signals) & Modbus versions also available

ADSYS96-24D 24VDC

ADSYS96-110D 110VDC

ADSYS96-220A 220VAC

SYSTEM 96

SPOT LED INDICATOR SYSTEM for use with PLC, MULTI 16 PLUS or AEM4

- All long life LED indications
- Number of indications from 8 to 16 per module and modules can be increased to any number. (8 indications per module is standard)
- Industrial numbered terminals make for rapid wiring.
- Custom ribbon termination types available to PLC manufacturers so that complete indication systems can be plugged in 1 cable.

- Multiplexed version available (on special order). Each unit operates from an 8 way central unit which has 18 terminals. (8 Data lines, 8 strobe lines and 2 power lines). From this, 7 extension units of 8 indications each can be driven, giving a total of 64 indications for 16PLC outputs.

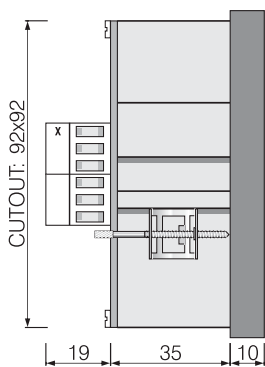

Cutout

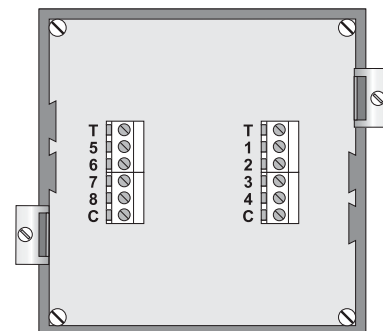
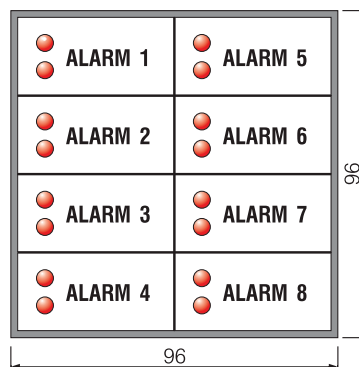

SYSTEM 248



S - Normally Stock
L - Limited Stock
O - Ex Order



DISPLAY SYSTEMS

Using our tile and grid system there are many different LED indicator systems available to suite your needs. We can fully rear illuminate the following tile sizes: 24x24, 24x48 & 48x48mm

Colours:

Red, Green, Yellow, Blue or White

There are also various options regarding the surround of this system.

Edge tile, Aluminium T-section or our new Alutec type T-section that matches our Alutec Enclosures.

See our "Mimic Crafts" catalogue for more information.

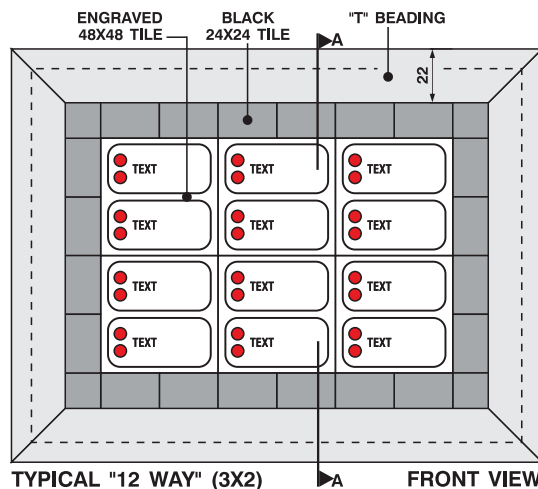
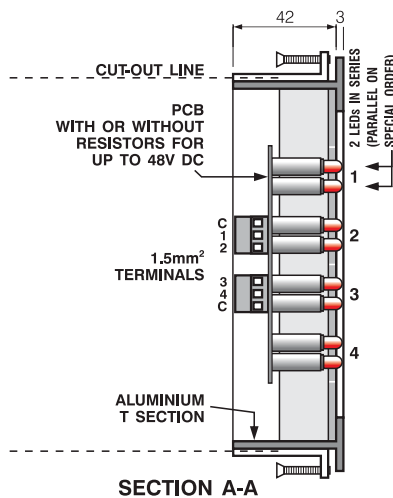

SPOT LED INDICATOR SYSTEM for use with PLC, MULTI 16 PLUS or AEM4

SYSTEM 248-BL

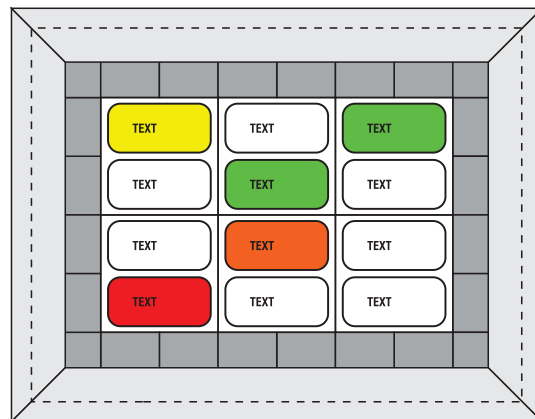

ADDA APM4



S - Normally Stock
L - Limited Stock
O - Ex Order



4 WAY MODULAR PANEL MOUNT ALARM ANNUNCIATOR SYSTEM

The Adda APM4 micro controller based alarm annunciator system was designed for use as an industrial panel mount alarm system. This modular system comprises of 4 way panel mount alarm modules which wire directly to the field. The system comprises of a control unit which houses the pushbuttons, inputs and power supply inputs as well as potential free contacts for the horn and trip functions. The alarm units consist of 4way alarm modules with field inputs and integrated displays. One control unit can drive up to 16 slave units , thus expanding the alarm unit to a 64 way alarm. With custom ribbon cables this limit can be extended to above 150 alarms.

Main functions:

- Each input provides for normally open or normally closed alarms via Dip-switch.
- Each unit provides for normally on (inverse) led drive e.g. For use as Mains On alarms etc. (Jumper setting on rear of unit)
- All slave modules have dip-switch settings for the following control options: First on fast flash / Manual or Auto reset / ringback / and input fast or slow response time.
- The system is modular expandable - up to 64 slave units.
- The units are interconnected via a standard 10-way ribbon system.
- The master unit has pushbutton facilities for Lamp Test / Accept / Reset inputs as well as potential free relay contacts for Horn and Trip outputs.
- Optional opto-coupled inputs with additional external PSU.



ALARM UNIT
(Bezel 48x144mm)
(Cutout 44x138mm)

CONTROL UNIT
(Bezel 48x144mm)
(Cutout 44x138mm)

MODEL	DESCRIPTION	DIMENSIONS(LxWxH)
A-TRIP10	10 WAY CARD	(120x90x50)
A-TRIP8	8 WAY CARD	(120x90x50)
A-TRIP6	6 WAY CARD	(81x90x50)
A-TRIP5	5 WAY CARD	(70x90x50)
A-TRIP4	4 WAY CARD	(70x90x50)
A-TRIP3	3 WAY CARD	(50x90x50)
A-TRIP2	2 WAY CARD	(50x90x50)

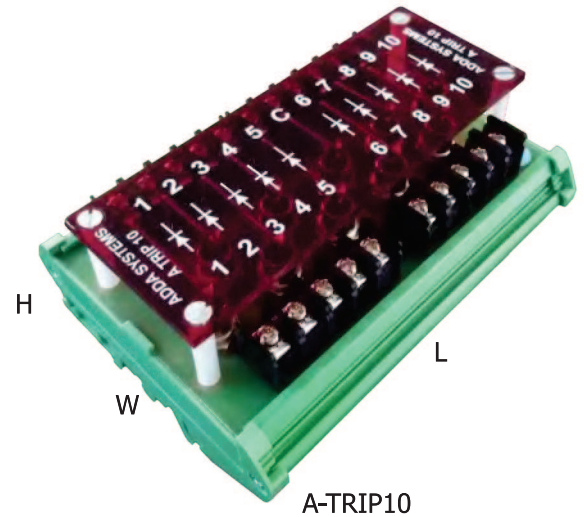

We supply a range of CURRENT TRIP STEERING AVALANCHE DIODE boards rated at 25 Amp 1600V.

The boards are supplied in 10, 8, 6, 5, 4, 3 & 2 way Din rail boated units. The reason for using avalanche diodes is that during the opening and closing of large circuit breakers very high back EMF surges can be developed. If normal rectifiers were used for current steering they would work once and on application of the very high Back EMF the diodes could be destroyed preventing them from working correctly a second time.

Since the TRIPPING system is mainly a safety concern it is important that it always works correctly. To ensure this Avalanche Rectifiers are used which work as normal rectifier diodes up to the PIV (1600V) and for transient voltages above that the diode breaks down like a Zener Diode, passes the current and then heals back to its original state ready for its next use.

The diodes are specified at 25 Amps but as they are not on a heatsink they are only rated for intermittent use in this application.

For normal use the diode boards are supplied wired as discreet diodes but on special order they can be wired with the Anodes of all the diode on the board connected to a common terminal.

Specifications

Symbol	Ratings	Unit
V_{RRM}	1600	V
I_{RRM}	6	mA
$I_{F(AV)} (^{\circ}C)$	25 (120)	A
I_{FRMS}	39	A
$I_{FSM} (10ms)$	0.34	kA
I^2t	0.58	$A^2s \cdot 10^3$
V_{FM} / I_{FM}	1.35 / 78	V / A
$V_{T(TO)}$	0.90	V
PRSM 100mks	2.5	kW
T_{jmax}	160	$^{\circ}C$
$R_{th(j-c)}$	1.100	$^{\circ}C / W$
M_d	0.9-1.1	Nm
w	0.006	kg

This is a 10 way diode board that can be supplied in 2 formats, for mounting on DIN Rail. Normally used for combining multiple TRIP signals to a single output to drive a Trip Relay.

a). As 5,8 or 10 individual diodes.

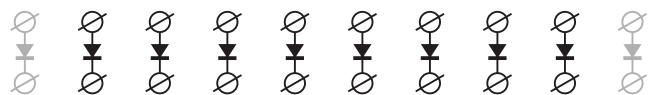

b). Diodes with anodes connected to a common.

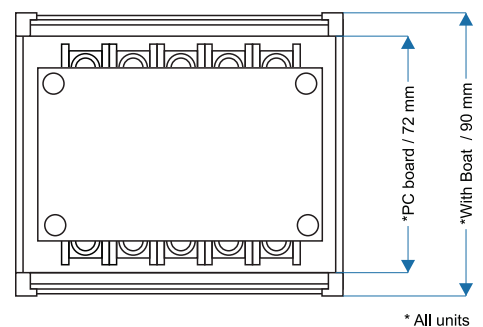
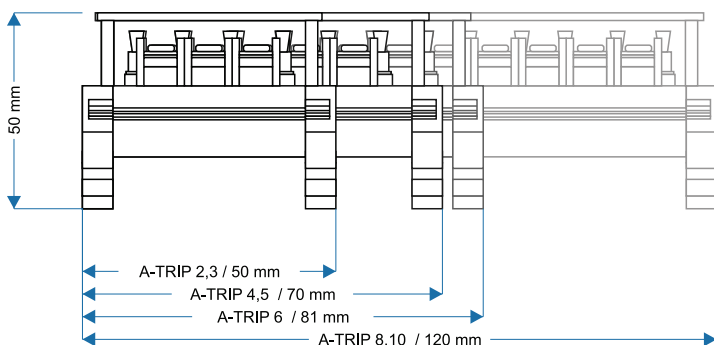
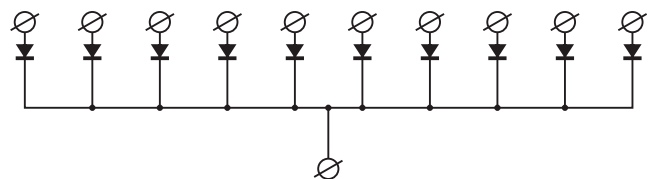

The AEM4+D micro controller based alarm annunciator system was designed for use as an industrial rail mount alarm system. This modular system comprises of DIN Rail Boated modules which wire directly to the field. The system comprises of a master unit which consists of the user pushbutton inputs and supply inputs as well as potential free contacts for the G.A. (Horn) and Trip functions. The slave units consist of 4way alarm modules with field inputs and display output drives. One master unit can drive up to 32 slave units, thus expanding the alarm unit to a 128 way (maximum) alarm system.

The unit has been designed so that no covers have to be removed for programming but the DIP Switches are not accessible in normal use as they are covered by the next module.



Power supply:

Supply voltage	24Vdc or 12V ±10%
Slave current consumption (leds)	80mA (max) / module
Slave current consumption (lamps)	20mA + (4* lamp current)/module
Master unit current consumption	90mA (max)

Module Dimensions

Width on Din Rail	50 mm
Length across Din Rail	122 mm
Height above top of Din Rail	50 mm

Alarm inputs:

Input voltage	24Vdc ±30%
Input current	4mA @ 24V (max)

Alarm Response Time:

Fast response.	Nominal 4 m Secs. Actual 3.8m Secs.
Slow response.	Nominal 0.5 Secs. Actual 0.48 Secs.

Alarm outputs:

Open collector type outputs.	
Max. Output current (led mode)	17mA each
Max output current (lamp mode)	50mA each
Total system max current	2A (all lamps + leds)

Relay outputs:

Horn relay	SPST Contact rating 2A @ 250Vac
Trip output	SPDT Contact rating 2A @ 250Vac

Operating Temperature:

When operating in the LED Output Mode @ a load of less than 25mA the unit can operate in ambient temperature of greater than 45°C

AEM4 Alarm Annunciator

The Aem4 micro controller based alarm annunciator system was designed for use as an industrial rail mount alarm system. This modular system comprises of 11Pin plug-in modules which wire directly to the field. The system comprises of a master unit which consists of the user pushbutton inputs and supply inputs as well as potential free contacts for the horn and trip functions. The slave units consist of 4way alarm modules with field inputs and display outputs. One master unit can drive up to 32 slave units, thus expanding the alarm unit to a 128 way(maximum) alarm.

Each input provides for normally open or normally closed alarms via a base mounted dip-switch. Each unit provides for normally on (inverse) led drive e.g. For use as Mains On alarms etc. This is an internal jumper setting. All slave modules have dip-switch settings for the following control options: First on fast flash / Manual or Auto reset / Ringback / and input fast or slow response time. The system is modular expandable - up to 32 slave units. All connections are via standard 11PIN relay bases. The units are interconnected via a standard 10-way ribbon system. The master unit has pushbutton facilities for Lamp Test / Accept / Reset inputs as well as potential free relay contacts for Horn and Trip outputs.



Power supply:

Supply voltage	24Vdc ±10%
Slave current consumption (leds)	80mA (max) / module
Slave current consumption (lamps)	20mA + (4* lamp current)/module
Master unit current consumption	90mA (max)

Alarm inputs:

Input voltage	24Vdc ±30%
Input current	7mA @ 24V (max)

Alarm outputs:

Open collector type outputs.	
Max. output current (led mode)	17mA each
Max output current (lamp mode)	50mA each
Total max current	2A (all lamps+ leds)

Relay outputs:

Horn relay	SPST
Trip output	SPDT
Contact rating	2A @ 250Vac

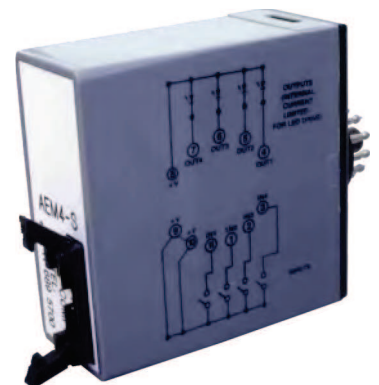



S - Normally Stock
L - Limited Stock
O - Ex Order



This is a 12 or 24V DC, Relay based, Full Function Alarm Annunciator Card which is ideal for smaller applications where alarm annunciation is required, e.g. on mimics or control panels.

Each **ARM 4P** Card drives 4 LEDs; 20 cards can be driven by one control card **ARM-CON** which contains all common circuits and a flasher. It is available from the factory in Automatic or Manual reset models. It can be used in an existing 24V DC system but it should be noted that the LEDs require positive common connection. The "Test Accept" button accepts alarms and also provides lamp test. A full system requires 12 or 24VDC, an ARM Card for every 4 ways, 1 control card, a buzzer, an accept button (and also a reset button in the case of a Manual Reset model).

The **System** operates on a normally open contact which closes on fault. On receipt of a closing contact the hooter sounds and the appropriate LED flashes. On acceptance, the hooter silences and the LED goes steady.

- In the 'Auto Reset' model the LED goes out when the fault clears.
- In the 'Manual Reset' model the LED stays on until the reset button is pressed.
- In either case, fleeting alarms are latched until accepted.
- Subsequent alarms are recognized, i.e. if there are alarms on the system, a new alarm will initiate a flashing LED and sound the hooter, without affecting existing alarms.
- If a panel mount self contained alarm annunciator is required see "ADDA 8", and
- for a large system see our "MULTI 16 PLUS" which can drive 1008 LEDs and
- incorporates advanced features.
- Also see our "MF 1", a motor flasher card which is ideal for motors that require
- steady run indication which flashes on trip and initiates a hooter.

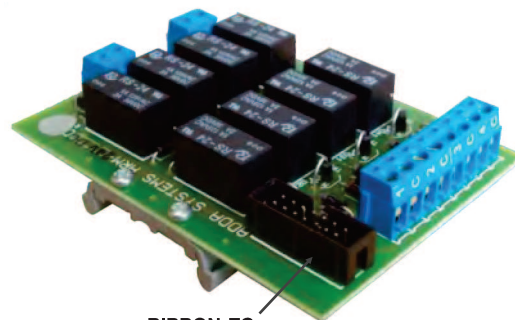
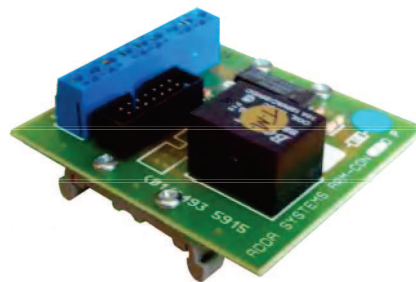

RIBBON TO "ARM-CON" CONTROL CARD

SASB-12B-N 12VDC (Neg. comm.)

SASB-24B-N 24VDC (Neg. comm.)

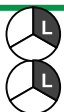

S - Normally Stock
L - Limited Stock
O - Ex Order



S - Normally Stock
L - Limited Stock
O - Ex Order

SIMPLE ALARM CARD - 8 WAY

This is an 8 way Alarm Card with Lamp Test and subsequent Buzzer output. It has been designed primarily as a driver for remote active repeat Mimics for fire Panels and other similar alarm systems where there is a Latched output. It provides an economical method of indicating alarms on a mosaic panel or alarm window display. LED's do not flash and fleeting alarms are not latched (when the signal goes, the LED goes out).

It is much better than a simple diode steered alarm card in that it also indicates subsequent alarms by restarting the buzzer every time a new alarm arrives, even if existing alarms are still present.

It incorporates lamp test, LED ballast resistors and a horn driver. It is available in 12V and 24V DC versions.

APPLICATIONS:

Fire alarm & other alarm annunciator repeat panels.

Process controlled applications where operators need to be made aware of new events but a full alarm annunciator is not required. This unit combined with a standard Lamp test card will provide a low cost solution for Motor run/ Trip indication. IE: Use the Standard Lamp test card for the steady state RUN indications and the SASB Alarm card for the Overload Latched Trip circuits.

See; Door Monitoring Modules, AEM4 Modules.

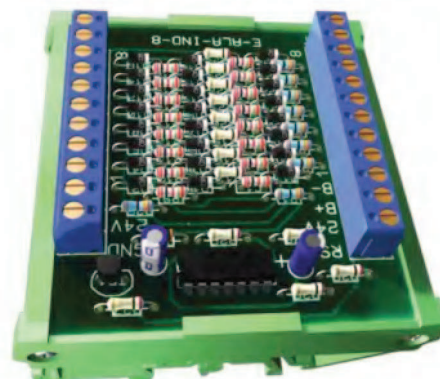

CONNECTION & WIRING DIAGRAM

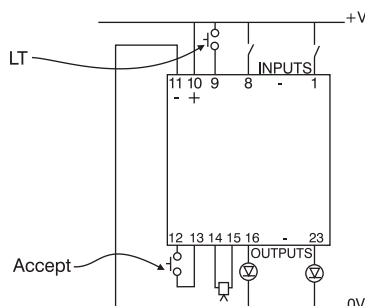

WIRING MULTIPLE SASB CARDS TO COMMON SWITCHES & BUZZER

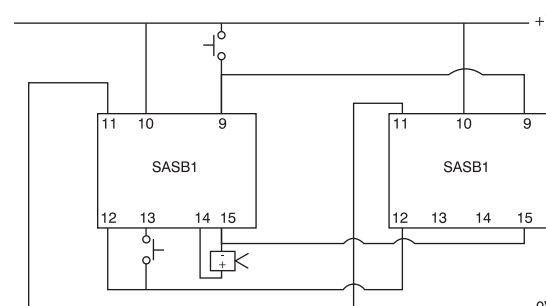

ALARM & MODBUS SYSTEMS

ADDA 4C/12C/20C

L S - Normally Stock
L - Limited Stock
O - Ex Order



ALARM ANNUNCIATORS WITH CONTROLS FOR HIGH VOLTAGE

Developed by MIMIC COMPONENTS, this alarm annunciator has been designed specifically for use with High Voltage Panels which normally operate with a battery supplied control voltage of 110V DC.

The main distinguishing feature is ADDA's extremely low current consumption, hence battery power is conserved and this in turn enables the unit to operate directly off 110V DC with very little heat.

ADDA can be supplied in modular compact modules (96x96mm) either 4 ways or 8 ways, which can be added together to make up any reasonable quantity of alarm points.

The standard unit is made for 110V DC, however 12V - 24V - 32V - 48V - 60V DC units are also available.

The system operates on a normally open contact which closes on fault. On receipt of a closing contact, the hooter sounds and the appropriate LED flashes. On acceptance, the hooter silences and the LED goes steady. In the Auto-Reset model the LED goes out when the fault clears. In the Manual Reset model, the LED stays on until the Reset button is pressed. In either case, fleeting alarms are latched until accepted.

Subsequent alarms are recognized, i.e. If there are alarms on the system, a new alarm will initiate a flashing LED and sound the hooter without affecting existing alarms.

The aim of the ADDA is to plug the gap in the market between the imported flag relays (which are expensive), and the industrial alarm annunciators. It also provides a locally manufactured unit designed specifically for reliable and immune operation in H.T. switch gear panels.

Using conventional Industrial Alarm Annunciators for 110V DC is not satisfactory as they usually operate on 24V DC and thus require an expensive and often unreliable DC to DC converter.

ADDA 4C

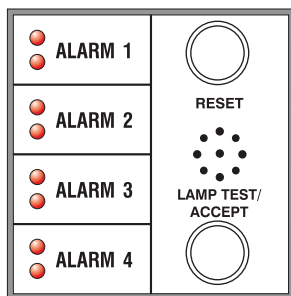

ADDA 20C

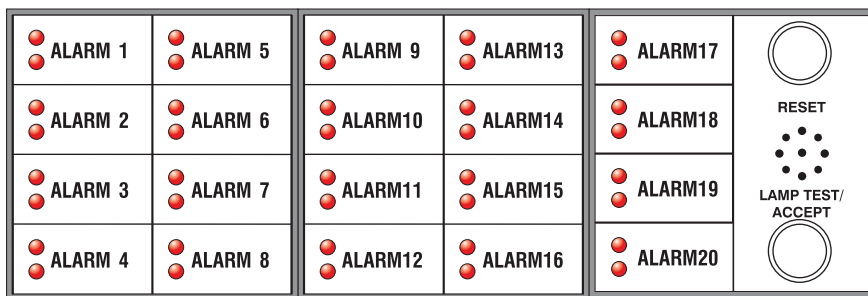

ADDA 4C LEGEND BACKPLATE

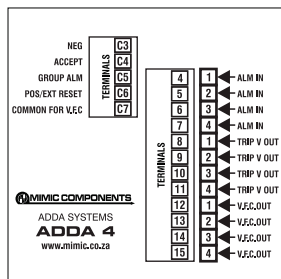

ADDA 20C LEGEND BACKPLATE

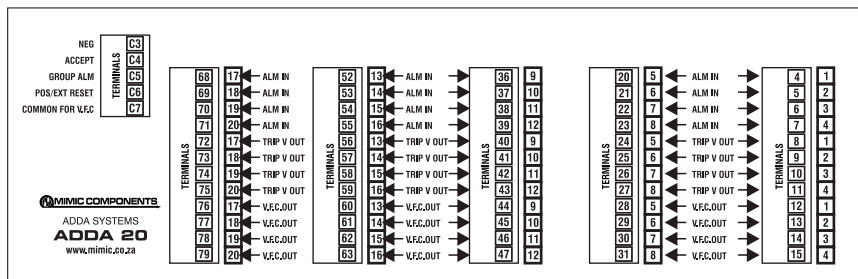

ADDA 12C

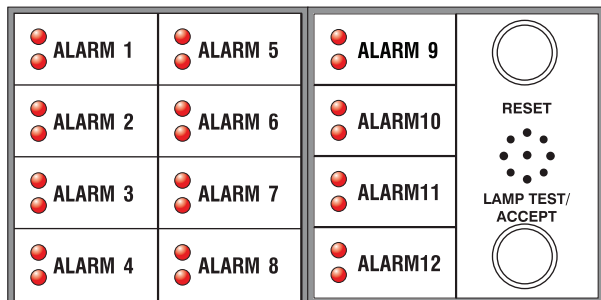

ADDA 12C LEGEND BACKPLATE

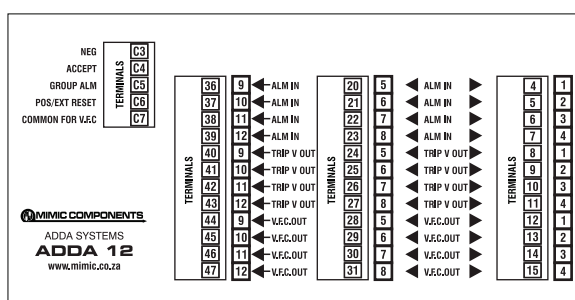

ALARM & MODBUS SYSTEMS

ADDA 4C/12C/20C

S - Normally Stock
L - Limited Stock
O - Ex Order



ALARM ANNUNCIATORS WITH CONTROLS FOR HIGH VOLTAGE

AVAILABLE IN MANUAL OR AUTO-RESET MODELS, & FOR OPERATION ON 12, 24, 32, 48, & 110V DC.

THIS UNIT IS ONLY SUITABLE FOR NORMALLY OPEN FIELD CONTACTS THAT CLOSE ON FAULT

Max. current draw from terminals 3, 8 to11, 16, 19, 24 to 27 is 250mA. **Group Alarm** is positive out at supply voltage 250mA, for Horn etc. In the **Auto-Reset** model there is no Reset button & positive is connected directly to terminal 2.

EXTENDED

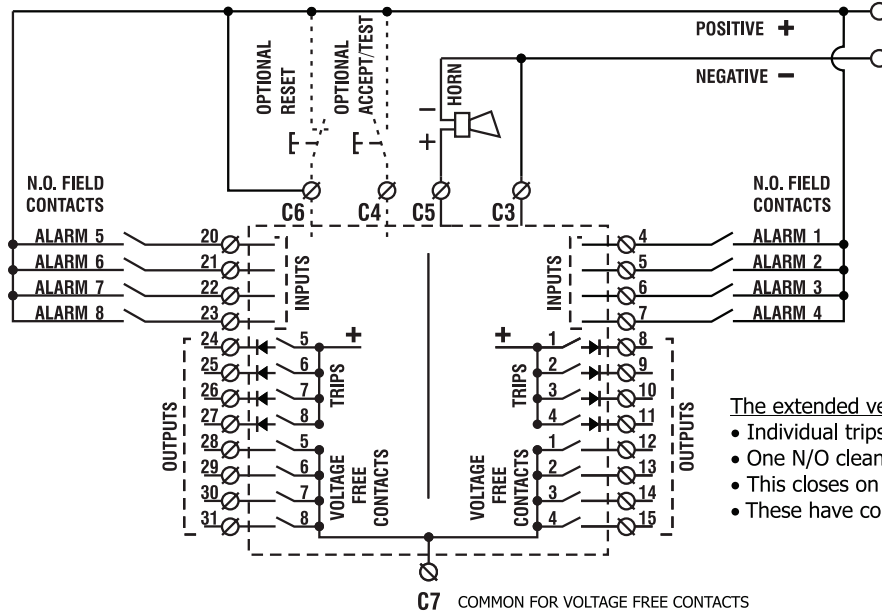

The extended version offers:

- Individual trips per alarm circuit.
- One N/O clean contact per alarm (12, 13, 14, 15, 28, 29, 30, 31).
- This closes on receipt of fault and opens when the fault is reset.
- These have common C7.

TYPICAL WIRING

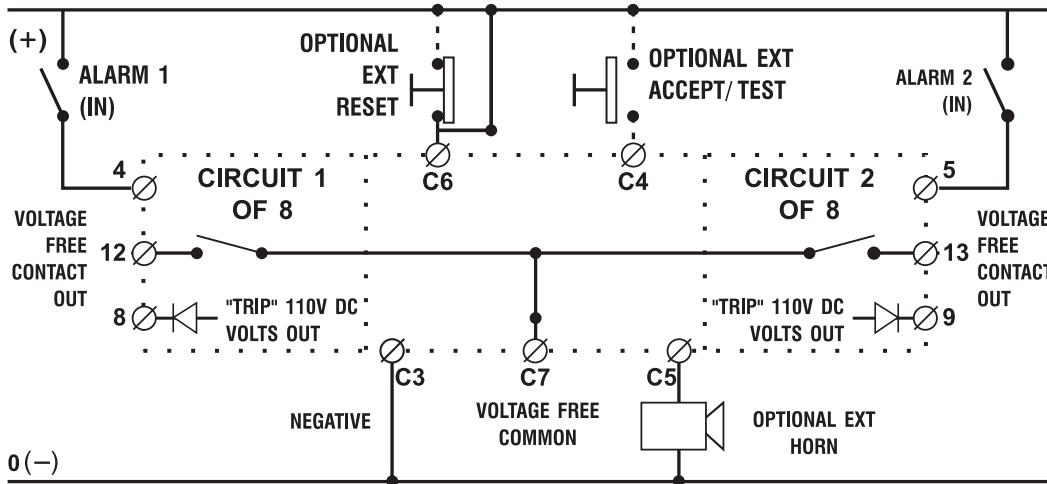

C4: Optional Accept
C6: Pos or Optional Reset

MANUAL RESET

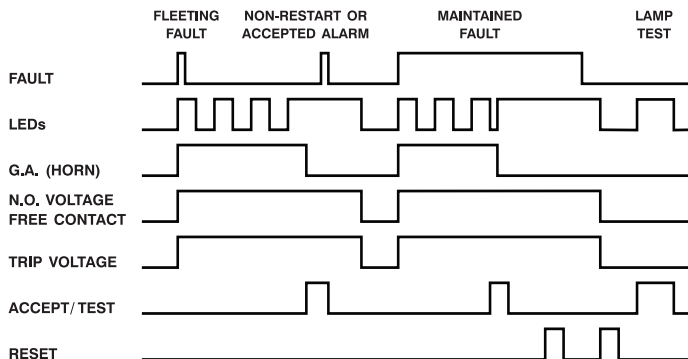

NOTE: MAXIMUM CURRENT DRAW FROM TRIP OUTPUTS IS 200mA. INDIVIDUAL TRIPS MAY BE GROUPED (WIRED OR 'ED). I.E. FOR DELAYED AND NON-DELAYED TRIPS THEY CAN BE GROUPED & THE DELAYED GROUP FED TO AN EXTERNAL TIME RELAY.

AUTOMATIC RESET

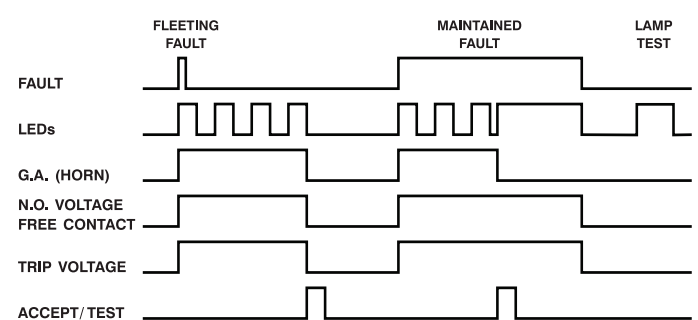

NOTE: MAXIMUM CURRENT DRAW FROM TRIP OUTPUTS IS 200mA. INDIVIDUAL TRIPS MAY BE GROUPED (WIRED OR 'ED). I.E. FOR DELAYED AND NON-DELAYED TRIPS THEY CAN BE GROUPED & THE DELAYED GROUP FED TO AN EXTERNAL TIME RELAY. RESET INPUT BECOMES POSITIVE (+) INPUT.

ALARM & MODBUS SYSTEMS

ADDA 8/16/24

S - Normally Stock
L - Limited Stock
O - Ex Order



ALARM ANNUNCIATORS FOR HIGH VOLTAGE

ADDA 8

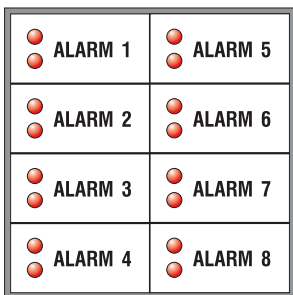

ADDA 24

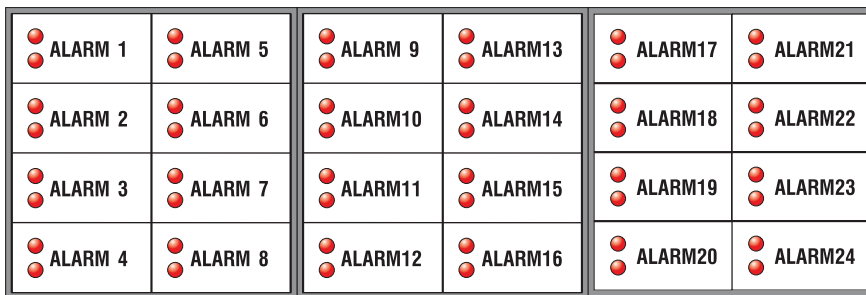

ADDA 8 LEGEND BACKPLATE

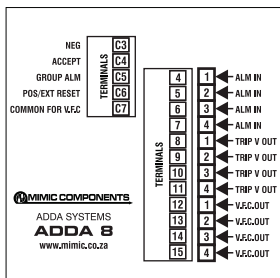

ADDA 24 LEGEND BACKPLATE

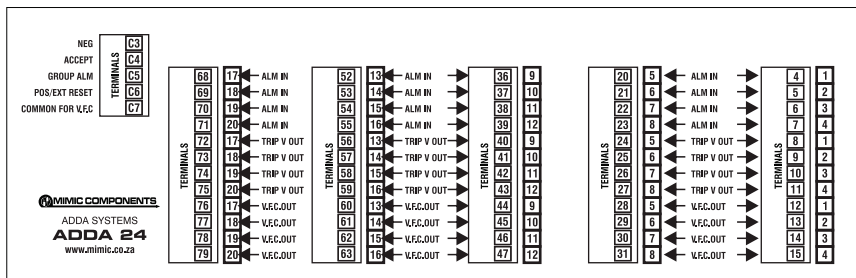

ADDA 16

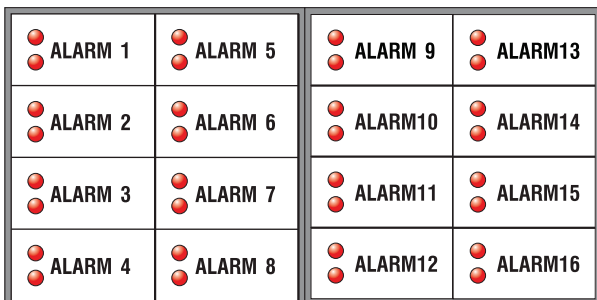

ADDA 16 LEGEND BACKPLATE

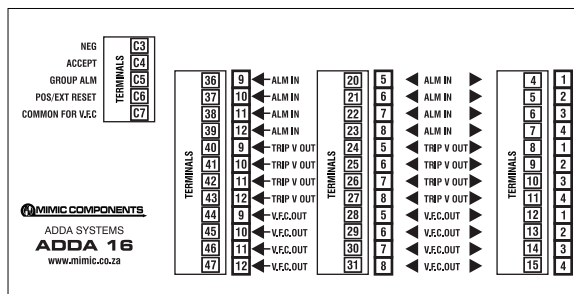

V+

V+

At supply voltage - 1 diode drop maybe "wired" together max current 250mA

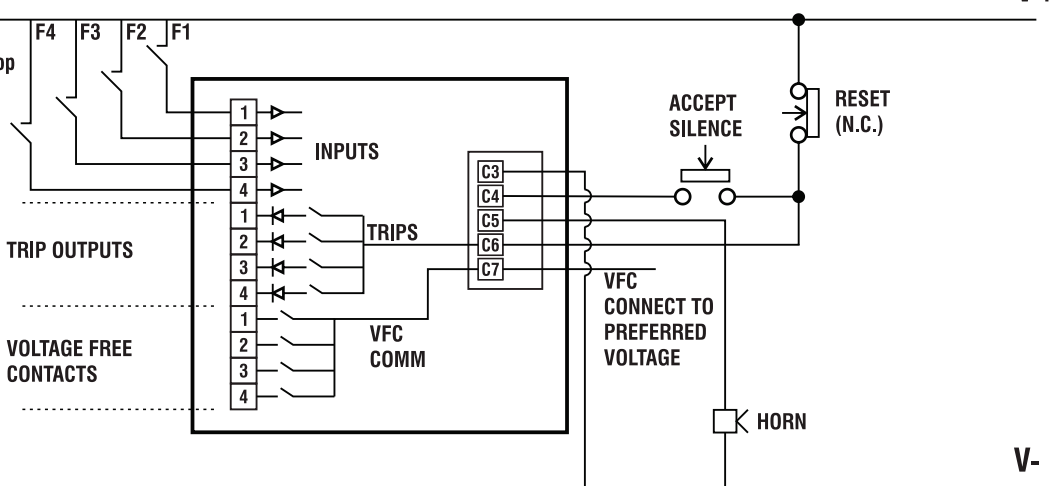

AD8G-24D (24DC)

AD8G-110A (110VAC)

AD8G-220A (220VAC)

S - Normally Stock
L - Limited Stock
O - Ex Order



ADDA 8G - ALARM ANNUNCIATOR

The ADDA 8 G alarm annunciator was specifically designed as an addition to our standard range of alarm annunciators to provide a low cost reliable unit for use where potential free alarm relay contacts in the field are provided.

This alarm annunciator uses a standard alarm sequence (I.S.A standard alarm sequence A-14) i.e. on receipt of fault, a siren sounds and the appropriate LED flashes; on acceptance the siren stops and the Led goes to the steady state. When the fault is corrected the Led extinguishes. Subsequent faults start the same sequence and previous accepted alarms stay as is.

These alarm units all have internal power supplies and can quite simply be ADDED together to make up a larger alarm system. The basic alarm unit can be used in conjunction with external pushbuttons for "ACCEPT" and "LAMP TEST" as well as an external buzzer and will provide 8 alarm circuits each. The pushbutton module alarm provides 4 alarm circuits as well as internal buzzer with volume adjustment and two front panel pushbuttons for the "ACCEPT" and "LAMP TEST" functions.

- Internally protected inputs
- Jumper selectable for normally open or normally closed inputs.
- 24DC/110/220VAC internal power supplies
- Fully expandable
- Synchronized flash
- Uses standard engraving material for front panel legends
- Strong aluminium extruded enclosures
- Potential free relay output for sirens etc.
- Simple reliable and compact (only 96mmx96mm for 8 way).
- 92 x 92mm Cutout



NOTE: Engraving of front panel is free if details are supplied on order, otherwise engraving is R 9-75 per alarm window.

GENERAL WIRING

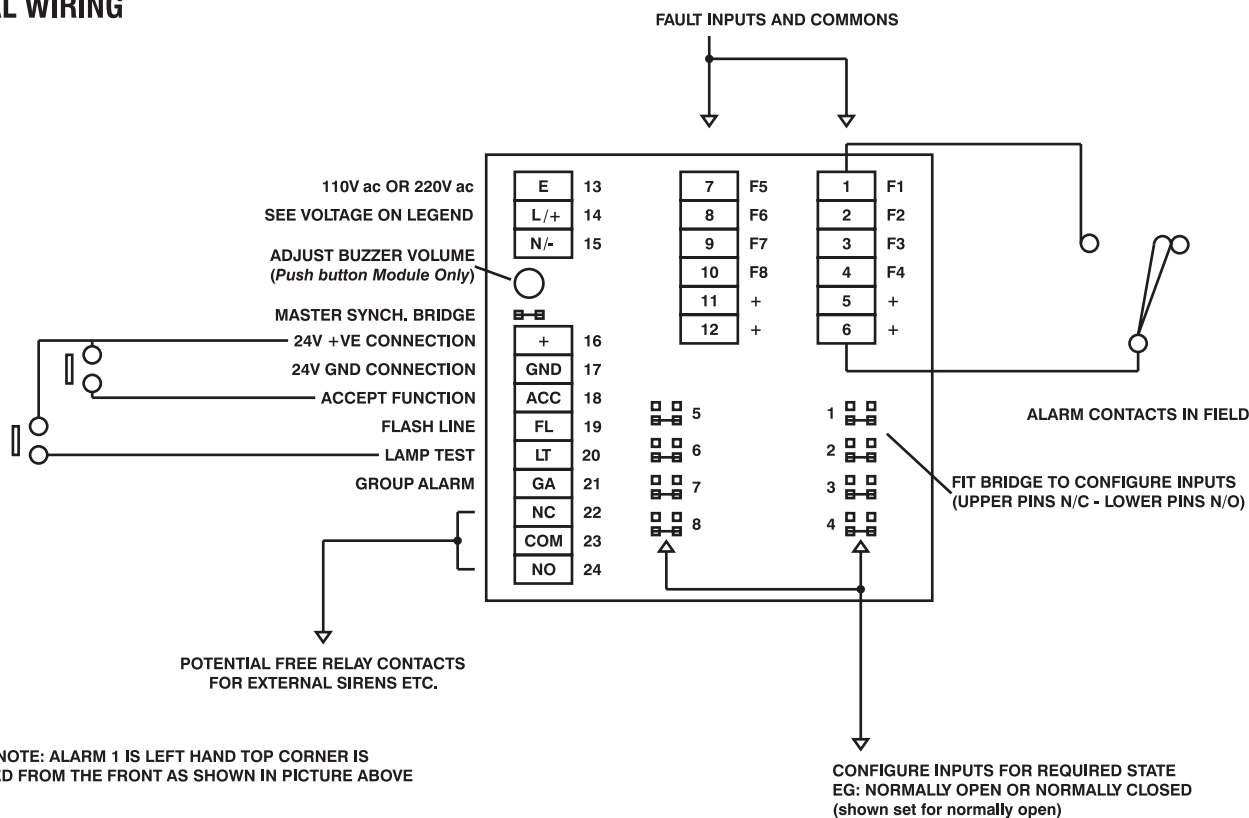

The ADDA 8-F is a purpose designed 110 /220 Vdc relay based flag unit for panel mounting purposes. The complete unit is housed in an extruded aluminium enclosure with removable front engraving plate for easy customization to the clients requirement. All terminations to the unit are via locking removable terminals for easy installation and maintenance. The 8 way flag unit consists of eight individual latching relay based circuits. Each circuit offers the following output functions:

1. Individual potential free contact (only the common of the contact is common to other circuits.)
2. Instantaneous avalanche diode protected trip output for each two grouped alarms (alarms 1,2 - 3,4 - 5,6 - 7,8 are grouped together)
3. Individual double switched trip reinforcing contact (for improved dc load breaking) for each alarm (the common of these contacts are also grouped in pairs as before.)
4. Two high brightness LED alarm indicators for each alarm on the front panel.

All these alarm output functions are available at the output terminals on the rear of the enclosure , as well as the input and power connections. All the plug-in terminals are of the screw-down locking type, to prevent the plugs from becoming unsocketed while in operation and thus invalidating the safety tripping circuits.

ADDA 8F - Electrical Operation

On application of the supply voltage all alarms will be in the off condition and all outputs will be de-activated. When an alarm input (+110/220 Vdc) is applied to one of the "fault in" inputs , that particular alarm will trip. This activates that relevant alarm's outputs and illuminates the two LED's on the front panel. The alarm will remain in this condition regardless of the input status , until the main power to the alarm unit is removed.(Reset) All the alarm inputs function in the same manner. (The alarm inputs are protected against false alarm triggering due to transients and inductive pickup by means of positive temperature coefficient resistors in parallel with the input relay coils.)

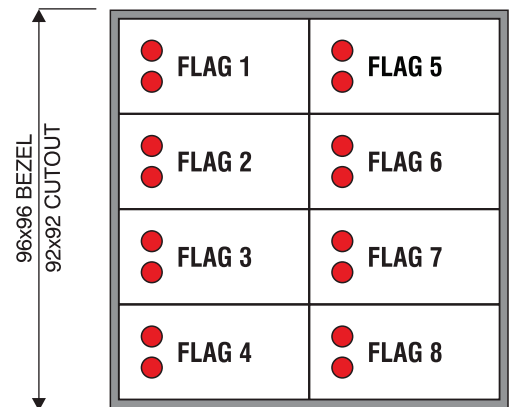
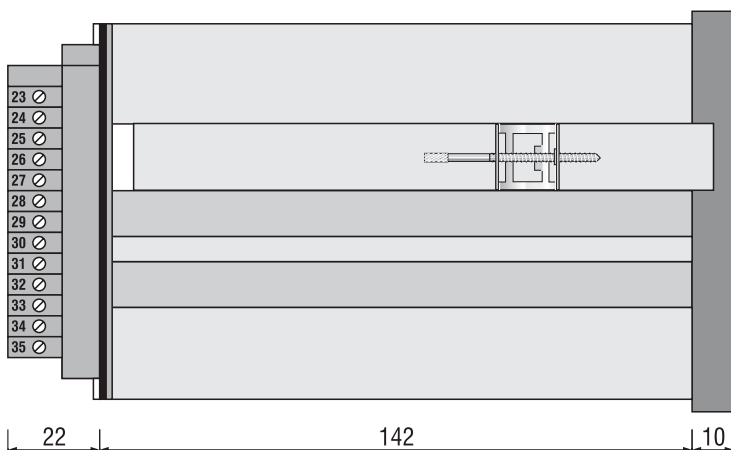

Note: Engraving of Front Panel is free if details are supplied on order, otherwise engraving will be charged for.

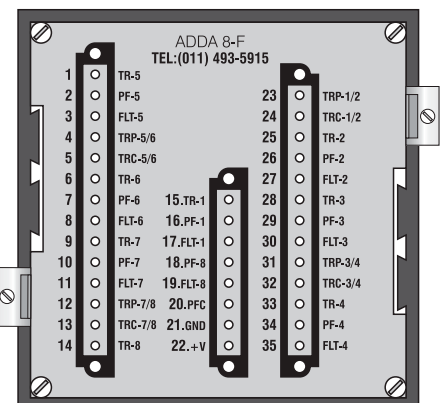
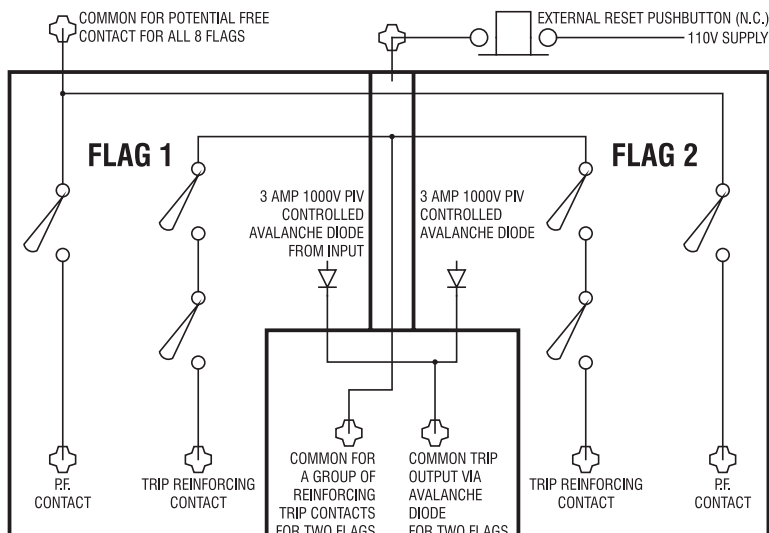

REAR

ALL CONTACTS ARE 5 AMP RATING (AC NOMINAL) WITH DC1 LOAD BREAK AS FOLLOWS:
55V DC=700mA, 110V DC=260mA & 220V DC=100mA

JOHANNESBURG

MIMIC COMPONENTS

ELECTRICAL & ELECTRONIC
WHOLESALE DISTRIBUTORS
SOUTHERN AFRICA

Address

5 Ramsay Street, Booyens,
2091 Johannesburg,
South Africa

P.O. Box 38493 Booyens,
2016 South Africa

Telephone

Switchboard: +27 (0)11- 689-5700
Fax: +27 (0)11- 493-8821

Email: sales@mimic.co.za

Website: www.mimic.co.za

CAPE TOWN



MIMIC CAPE

ELECTRICAL & ELECTRONIC
WHOLESALE DISTRIBUTORS
SOUTHERN AFRICA

Address

Unit 41A, Stella Park,
57 Stella Road, Montague Gardens,
Cape Town, 7441, South Africa

PO. Box 36955 Chempet,
7442 South Africa

Telephone

Switchboard: +27(0) 21-551-8185
Facsimile: +27(0) 21-551-8169

Email: anje@mimics.co.za

Website: www.mimic.co.za



MIMIC COMPONENTS sales@mimic.co.za www.mimic.co.za TEL: (011) 689-5700
5 Ramsay Street, Booyens, 2091, Johannesburg, South Africa / P.O. Box 38493, Booyens, 2016, Johannesburg, South Africa / FAX: (011) 493-8821



MIMIC CAPE anje@mimics.co.za www.mimic.co.za TEL: +27(0)21-551-8185 FAX: +27(0)21-551-8169
Unit 41A, Stella Park, 57 Stella Road, Montague Gardens, Cape Town 7441. PO Box 36955 Chempet 7442, South Africa